

Driver Manual

FS-8700-72 Secutron

APPLICABILITY & EFFECTIVITY

Effective for all systems manufactured after March 2021.



Driver Revision: 1.02
Document Revision: 3.A



fieldserver

MSA Safety
1991 Tarob Court
Milpitas, CA 95035
Website: www.MSAsafety.com

U.S. Support Information:
+1 408 964-4443
+1 800 727-4377
Email: smc-support@msasafety.com

EMEA Support Information:
+31 33 808 0590
Email: smc-support.emea@msasafety.com

Contents

1	Description	4
2	Driver Scope of Supply	4
	2.1 Supplied by MSA Safety.....	4
3	Hardware Connections	5
4	Data Array Parameters	6
5	Client Side Configuration	7
	5.1 Client Side Connection Parameters	7
	5.2 Client Side Node Parameters.....	8
	5.3 Client Side Map Descriptor Parameters.....	8
	5.3.1 FieldServer Specific Map Descriptor Parameters.....	8
	5.3.2 Driver Related Map Descriptor Parameters.....	8
	5.3.3 Timing Parameters.....	8
	5.4 Map Descriptor Example	9
6	Server Side Configuration	10
	6.1 Server Side Connection Parameters.....	10
	6.2 Server Side Node Parameters.....	10
	6.3 Server Side Map Descriptor Parameters.....	11
	6.3.1 FieldServer Specific Map Descriptor Parameters.....	11
	6.3.2 Driver Specific Map Descriptor Parameters.....	11
	6.4 Map Descriptor Example	11
7	Troubleshooting	12
	7.1 Driver Messages, Error Messages and Optional Map Descriptors	12
8	Reference	13
	8.1 Event Function or Condition Codes.....	13
	8.2 Panel Circuit or Zone Numbers	14
	8.3 Panel Power-up, Restarts and Resets	15

1 Description

The Secutron Modul-R driver allows the FieldServer to transfer data to and from a Client and a Server panel on a single point to point network over RS-232 using Secutron Modul-R protocol.

The protocol is strictly command/response with the Client polling a Server device. A Server device can report the generation and clearing of alarms to the polling Client. One panel can be connected per FieldServer port. The driver supports networked panels. The Client Drive supports up to 1000 networked panels per port, but the Server driver only supports 10 panels due to memory limitations. A Server panel can consist of up to 100 circuits.

When an alarm is generated, a bit is set and when the alarm is cleared, the bit is cleared. The panel number is identified by the Node_ID in the configuration file.

Each circuit's alarms are represented by 32 unsigned quantities, which hold 1,024 bits. Only bits 0 to 999 may be used. The last 25 bits are reserved.

There are 3200 unsigned quantities per panel to represent the 100 circuits with 1000 devices per circuit. Each bit of the 32-bits in an unsigned quantity represents an alarm state (1 = alarm, 0 = normal).

A set bit indicates an alarm and the clearing of a bit indicates the reset of an alarm. A panel number is identified by the Node Id in the configuration files.

Panel, circuit and device numbers range from 0 in messages e.g.:

Panel numbers – 0 to 999

Circuit numbers – 0 to 99

Device numbers – 0 to 999

The Client driver is configured with three Map Descriptors. Each Map Descriptor must be of a certain "Secutron_Type". The following types and their functions are defined:

Secutron_Type	Map Descriptor Function
Poller	Polls the Secutron Modul-R at the configured scan interval.
Device	Stores alarm (Device) statuses.
Function	Stores the function or type of alarm that was triggered or restored.

The Server driver emulates a Secutron Modul-R panel and is configured through the use of two Map Descriptors:

Secutron_Type	Map Descriptor Function
Device	Stores alarm (Device) statuses.
Function	Stores the function or type of alarm that was triggered or restored.

The Server driver will respond with alarm statuses from the Device Map Descriptor. The Function Map Descriptor will return the type or function of the corresponding alarm reported by the Device Map Descriptor.

FieldServer Mode	Nodes	Comments
Client	Up to 1000 per port	Only one panel can be connected per port, but the driver supports up to 1000 networked panels.
Server	10	Max of 10 panels supported due to memory limitations.

2 Driver Scope of Supply

2.1 Supplied by MSA Safety

Part #	Description
	Driver Manual

3 Hardware Connections

The FieldServer is connected to the panels as shown below. Configure the panels according to manufacturer's instructions.

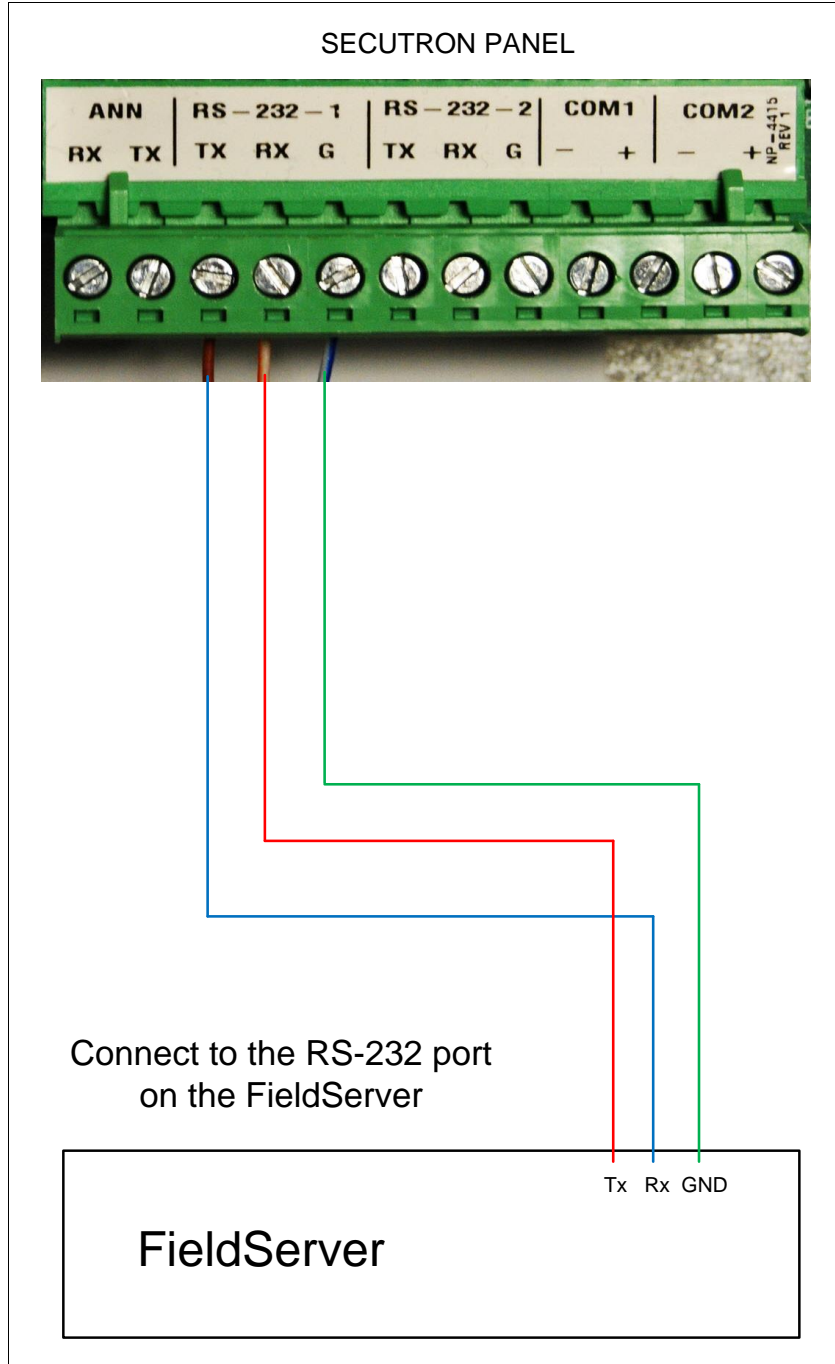

Connector Pinouts

RJ-45 Pin	From RJ-45	To Secutron
1	Brown	Tx
8	White/Orange	Rx
5	Blue/white	GND

4 Data Array Parameters

Data Arrays are “protocol neutral” data buffers for storage of data to be passed between protocols. It is necessary to declare the data format of each of the Data Arrays to facilitate correct storage of the relevant data.

Section Title		
Data_Arrays		
Column Title	Function	Legal Values
Data_Array_Name	Provide name for Data Array.	Up to 15 alphanumeric characters
Data_Array_Format	Provide data format. Each Data Array can only take on one format.	Float, Bit, Byte, Uint16, Uint32, Sint16, Sint32
Data_Array_Length	Number of Data Objects. Must be larger than the data storage area required by the Map Descriptors for the data being placed in this array.	1-10000

Example

```
// Data Arrays
Data_Arrays
Data_Array_Name , Data_Array_Format , Data_Array_Length
p1c1_devices , Bit , 1
p1c1_function , Byte , 1000
p1c69_restart , Bit , 1000
p1c69_function , Byte , 100
p1c90_reset , Bit , 100
p1c90_function , Byte , 100
```

5 Client Side Configuration

For detailed information on FieldServer configuration, refer to the FieldServer Configuration Manual. The information that follows describes how to expand upon the factory defaults provided in the configuration files included with the FieldServer (see “.csv” files on the provided with the FieldServer).

This section documents and describes the parameters necessary for configuring the FieldServer to communicate with Secutron Modul-R panels.

The configuration file tells the FieldServer about its interfaces, and the routing of data required. In order to enable the FieldServer for Secutron Modul-R driver communications, the driver independent FieldServer buffers need to be declared in the “Data Arrays” section, the destination device addresses need to be declared in the “Client Side Nodes” section, and the data required from the Servers needs to be mapped in the “Client Side Map Descriptors” section. Details on how to do this can be found below.

NOTE: In the following tables, * indicates an optional parameter and bold legal values are default.

5.1 Client Side Connection Parameters

Section Title		
Connections		
Column Title	Function	Legal Values
Port	Specify which port the device is connected to the FieldServer.	P1-P2, R1-R2 ¹
Baud*	Specify baud rate.	150, 300, 1200, 2400, 4800, 9600 (Vendor limitation)
Parity*	Specify parity.	None (Vendor limitation)
Data_Bits*	Specify data bits.	8 (Vendor limitation)
Stop_Bits*	Specify stop bits.	1 (Vendor limitation)
Protocol	Specify protocol used.	Secutron

Example

```
// Client Side Connections
Connections
Port          , Protocol    , Baud    , Parity
P1            , Secutron    , 9600    , None
```

¹ Not all ports shown are necessarily supported by the hardware. Consult the appropriate Instruction manual for details of the ports available on specific hardware.

5.2 Client Side Node Parameters

Section Title		
Nodes		
Column Title	Function	Legal Values
Node_Name	Provide name for node.	Up to 32 alphanumeric characters
Node_ID	Generic Node ID unique to port. Also used as panel number.	0-999
Protocol	Specify protocol used.	Secutron
Port	Specify which port the device is connected to the FieldServer.	P1-P2

Example

```
// Client Side Nodes
Nodes
Node_Name , Node_ID, , Protocol , Port
Node_1 , 1 , Secutron , P1
```

5.3 Client Side Map Descriptor Parameters

5.3.1 FieldServer Specific Map Descriptor Parameters

Column Title	Function	Legal Values
Map_Descriptor_Name	Name of this Map Descriptor.	Up to 32 alphanumeric characters
Data_Array_Name	Name of Data Array where data is to be stored in the FieldServer.	One of the Data Array names from "Data Array" section above
Data_Array_Offset	Starting location in Data Array.	0 to (Data_Array_Length-1) as specified in "Data_Array" section
Function	Function of Client Map Descriptor.	Rdbc, Passive_Client
Node_Name	Name of Node to fetch data from.	One of the Node Names specified in "Server Node Descriptor" above

5.3.2 Driver Related Map Descriptor Parameters

Column Title	Function	Legal Values
Secutron_Type	Identifies the type of data the Map Descriptor points to.	Poller, Device, Function
Secutron_Circuit	Identifies the circuit or panel zone.	0-99
Length	The number of devices on the circuit the Map Descriptor must detect.	0-999

5.3.3 Timing Parameters

Column Title	Function	Legal Values
Scan_Interval	Rate at which data is polled	>= 0s

5.4 Map Descriptor Example

Map_Descriptor_Name	Scan_Interval	Data_Array_Name	Data_Array_Offset	Function	Node_Name	Secutron_Type	Secutron_Circuit	Length
P1_POLLER	, 0s	, Poller	, 0	, Rdbc	, Node_1	, Poller	, -	, 1
P1C1_DEVICES	, -	, P1C1_DEVICES	, 0	, Passive_Client	, Node_1	, Device	, 1	, 200
P1C1_FUNCTION	, -	, P1C1_FUNCTION	, 0	, Passive_Client	, Node_1	, Function	, 1	, 200
P1C69_RESTART	, -	, P1C69_RESTART	, 0	, Passive_Client	, Node_1	, Device	, 69	, 100
P1C69_FUNCTION	, -	, P1C69_FUNCTION	, 0	, Passive_Client	, Node_1	, Function	, 69	, 100
P1C90_RESET	, -	, P1C90_RESET	, 0	, Passive_Client	, Node_1	, Device	, 90	, 100
P1C90_FUNCTION	, -	, P1C90_FUNCTION	, 0	, Passive_Client	, Node_1	, Function	, 90	, 100

In the above example:

- Map_Descriptor_Name – Any unique name. Name will appear in Bridge Map Descriptor status information screens.
- Scan_Interval – The rate at which the driver polls the panel.
- Data_Array_Name – A Data Array name must be found under Data_Arrays. Data from a circuit event will be stored in the array at Data_Array_Offset. The Poller Data Array will contain non-zero data when communications with the panel is OK.
- Function – Function must be read for pollers; all others are Passive_Client.
- Node_Name – A name given to the device to which the FieldServer is connected.
- Secutron_Type – The type of data the Map Descriptor points to. Device data contains alarm statuses. Function data contains condition codes. Refer to **Section 8.1** for more information.
- Secutron_Circuit – The circuit or zone number used to trap incoming events into the Map Descriptor. See Driver notes.
- Length – The number of devices on the circuit this Map Descriptor can detect for incoming events.

6 Server Side Configuration

For detailed information on FieldServer configuration, refer to the FieldServer Configuration Manual. The information that follows describes how to expand upon the factory defaults provided in the configuration files included with the FieldServer (see “.csv” files provided with the FieldServer).

The configuration file tells the FieldServer about its interfaces, and the routing of data required. In order to enable the FieldServer for Secutron Modul-R driver communications, the driver independent FieldServer buffers need to be declared in the “Data Arrays” section, the FieldServer virtual node(s) need to be declared in the “Server Side Nodes” section, and the data to be provided to the Client needs to be mapped in the “Server Side Map Descriptors” section. Details on how to do this can be found below.

NOTE: In the tables below, * indicates an optional parameter with the bold legal value as default.

6.1 Server Side Connection Parameters

Section Title		
Connections		
Column Title	Function	Legal Values
Port	Specify which port the device is connected to the FieldServer.	P1-P2, R1-R2 ²
Baud*	Specify baud rate.	150, 300, 1200, 2400, 4800, 9600 (Vendor limitation)
Parity*	Specify parity.	None (Vendor limitation)
Data_Bits*	Specify data bits.	8 (Vendor limitation)
Stop_Bits*	Specify stop bits.	1 (Vendor limitation)
Protocol	Specify protocol used.	Secutron

Example

```
// Server Side Connections
Connections
Port          , Protocol   , Baud   , Parity
P1            , Secutron  , 9600   , None
```

6.2 Server Side Node Parameters

Section Title		
Nodes		
Column Title	Function	Legal Values
Node_Name	Provide name for node.	Up to 32 alphanumeric characters
Node_ID	Generic Node ID unique to port. Also used as panel number.	0-9
Protocol	Specify protocol used.	Secutron
Port	Port to which node belongs.	P1-P2

Example

```
// Server Side Nodes
Nodes
Node_Name      , Node_ID  , Protocol   , Connection
Node_1         , 1        , Secutron   , P1
```

² Not all ports shown are necessarily supported by the hardware. Consult the appropriate Instruction manual for details of the ports available on specific hardware.

6.3 Server Side Map Descriptor Parameters

6.3.1 FieldServer Specific Map Descriptor Parameters

Column Title	Function	Legal Values
Map_Descriptor_Name	Name of this Map Descriptor.	Up to 32 alphanumeric characters
Data_Array_Name	Name of Data Array where data is to be stored in the FieldServer.	One of the Data Array names from "Data Array" section above
Data_Array_Offset	Starting location in Data Array.	0 to (Data_Array_Length-1) as specified in "Data_Array" section
Function	Function of Client Map Descriptor.	Server
Node_Name	The name of the Node the Map Descriptor is attached to.	One of the Node Names specified in "Server Node Descriptor" above

6.3.2 Driver Specific Map Descriptor Parameters

Column Title	Function	Legal Values
Secutron_Type	Identifies the type of data the Map Descriptor points to	Device, Function
Secutron_Circuit	Identifies the circuit or panel zone	0-99
Length	The number of devices on the circuit the Map Descriptor must represent	0-999

6.4 Map Descriptor Example

Map_Descriptor_Name	Scan_Interval	Data_Array_Name	Data_Array_Offset	Function	Node_Name	Secutron_Type	Secutron_Circuit	Length
P1C1_DEVICES	,-	,P1C1_DEVICES	,0	,Passive	,Node_1	,Device	,1	,200
P1C1_FUNCTION	,-	,P1C1_FUNCTION	,0	,Passive	,Node_1	,Function	,1	,200
P1C69_RESTART	,-	,P1C69_RESTART	,0	,Passive	,Node_1	,Device	,69	,100
P1C69_FUNCTION	,-	,P1C69_FUNCTION	,0	,Passive	,Node_1	,Function	,69	,100
P1C90_RESET	,-	,P1C90_RESET	,0	,Passive	,Node_1	,Device	,90	,100
P1C90_FUNCTION	,-	,P1C90_FUNCTION	,0	,Passive	,Node_1	,Function	,90	,100

In the above example:

- Map_Descriptor_Name – Any unique name. Name will appear in Bridge Map Descriptor status information screens.
- Scan_Interval – The rate at which the driver polls the panel.
- Data_Array_Name & Data_Array_Offset – A Data Array name must be one found under Data_Arrays. Data from a circuit event will be stored in the array at Data_Array_Offset.
- Function – Function may not be read or write since it implements a Server. Function may only be Passive.
- Node_Name – A name given to the device to which the FieldServer is connected.
- Secutron_Type – The type of data the Map Descriptor points to. Device data contains alarm statuses. Function data contains condition codes. Refer to **Section 8.1** for more information.
- Secutron_Circuit – The circuit or zone number used to trap incoming events into the Map Descriptor. See Driver notes.
- Length – The number of devices on the circuit this Map Descriptor can detect for incoming events.

7 Troubleshooting

7.1 Driver Messages, Error Messages and Optional Map Descriptors

The Client driver will report all events it receives from the panel on the User Messages ► Driver screen.

If an event is received that has no corresponding Map Descriptor defined, this will be reported on the User Messages ► Error screen. This is a useful configuration tool to ensure that all required data is stored.

8 Reference

8.1 Event Function or Condition Codes

When the Client driver receives an event from the panel, it stores the event's function or condition code in the Secutron_Type=function Map Descriptor's Data Array at the device number's offset.

Example:

Device=3 on Circuit=1 goes into alarm – the Panel reports an event with function code A (Decimal 65).

- The Map Descriptor Secutron_Type=device, Secutron_Circuit=1 will set a bit and store the event function code A (Decimal 65) at offset 3 in the Map Descriptors' Data Array.
- The Secutron_Type=device Map Descriptors will set a bit if any of the events listed below occur on that circuit or zone. The bit will be cleared if the panel reports the event as cleared.

The following table lists the full list of event function codes:

ASCII Value	Decimal	Meaning
A	65	Alarm
B	66	Bypass
C	67	Comlink
D	68	Duplicate Addressable Device
E	69	Maintenance Alert
G	71	Ground Fault
H	72	Hot Key Pressed
I	73	Illegal Addressable Device
J	74	Switch
M	77	Missing Addressable Device
N	78	Non-Fire/Non-Reporting
P	80	Pull Station Alarm
Q	81	Releaser Abort
R	82	Releaser Halt
S	83	Supervisory
T	84	Trouble or Parameter Change
U	85	Wrong Device Type
W	87	Waterflow Alarm

8.2 Panel Circuit or Zone Numbers

The panel groups events under circuit or zone numbers. When setting up a Client configuration it is necessary to create Map Descriptors to trap the events from the zones or circuits you want to see data from.

If an event is received that has no corresponding Map Descriptor defined, this will be reported on the User Messages ► Error screen. This is a useful configuration tool to ensure that all required data is stored.

Panel Zone	Description	Panel Zone	Description
0	General Alarm	53	Comlink 3
1	Initiating Circuit 1	54	Comlink 6
2	Initiating Circuit 2	55	Printer Port
3	Initiating Circuit 3	59	Addressable Modules Comlink
4	Initiating Circuit 4	60	Output (bell/releaser) Supervision
5	Initiating Circuit 5	61	Auxiliary Power Supervision
6	Initiating Circuit 6	64 ³	Program Checksum
7	Initiating Circuit 7	65 ³	Database Checksum
8	Initiating Circuit 8	66	AC Power
9	Initiating Circuit 9	67	Low Battery
10	Initiating Circuit 10	69 ³	Program Restart
11	Initiating Circuit 11	71	Network Ground Fault
12	Initiating Circuit 12	80 ⁴	Privilege Level
13	Initiating Circuit 13	81	1st Stage Alarm
14	Initiating Circuit 14	82	2nd Stage Alarm
15	Initiating Circuit 15	83	Switch
16	Initiating Circuit 16	84	Test Mode
17	Initiating Circuit 17	85 ³	Erase Configuration
18	Initiating Circuit 18	86 ⁵	Change Configuration
19	Initiating Circuit 19	87	Passcode Tamper
20	Initiating Circuit 20	88 ³	Database Loaded
21	Initiating Circuit 21	89 ³	Time/Date Change
22	Initiating Circuit 22	90 ³	Hot Key Activation
23	Initiating Circuit 23	91 ³	Memory Overflow
24	Initiating Circuit 24	92 ³	Network Reboot
50	Network Verify	93 ³	New Program
51	Comlink 1	94 ³	Network Reboot Required who
52	Comlink 2	95 ³	Network Reboot Required why

³ These zones do not restore.

⁴ Privilege Level 0 generates a restore signal; all others generate a trouble signal.

⁵ This zone does not restore and is not repeated sequentially in the archive.

8.3 Panel Power-up, Restarts and Resets

When the panel powers up or is restarted it will send an event on zone/circuit 69 device 0.

When the panel is reset from the Hot Keys on the front panel, it will send an event on zone/circuit 90, device 9.

The Client driver will clear all the Secutron_Type=device and Secutron_Type=function Data Arrays when it traps any of these 2 events, provided the circuit 69 and 90 Map Descriptors have been set up as per the example Map Descriptors under the Client Side configuration instructions.

Other events for Circuits 69 and 90 are shown below for which a bit will be set in the Secutron_Type=device Map Descriptor's Data Array at the device offset values shown below:

Circuit	Events	
Program Restart (Circuit 69)	000 – Power On/Hard reboot	003 – Illegal Instruction
	001 - Watchdog	004 – Unused Interrupt
	002 – Clock Monitor	005 – Orphan Interrupt
Hot Key Activation (Circuit 90) Function number of the Hot Key pressed.	001 – Fire Drill	026– Switch 11 On
	002 - Lamp Test	027 – Switch 12 On
	003 – Releaser Disconnect	028 – Switch 13 On
	004 – Relay disconnect	029 – Switch 14 On
	005 – Test mode	030 – Switch 15 On
	006 – Signal Disconnect	031 – Switch16 On
	007 - Acknowledge	032 – Switch 1 Off
	008 – Signal Silence	033 – Switch 2 Off
	009 - Reset	034 – Switch 3 Off
	010 – Common Disconnect	035 – Switch 4 Off
	011 – General Alarm	036 – Switch 5 Off
	012 - Halt	037 – Switch 6 Off
	013 - Abort	038– Switch 7 Off
	013 – 2 nd Stage Inhibit	039– Switch 8 Off
	016 – Switch 1 On	040– Switch 9 Off
	017 – Switch 2 On	041– Switch 10 Off
	018 – Switch 3 On	042– Switch 11 Off
	019 – Switch 4 On	043 – Switch 12 Off
	020 – Switch 5 On	044 – Switch 13 Off
	021 – Switch 6 On	045 – Switch 14 Off
	022– Switch 7 On	046 – Switch 15 Off
	023– Switch 8 On	047 – Switch16 Off
	024– Switch 9 On	051 – Manual Restart
	025– Switch 10 On	